

## Project # 1 CATAPULT

**Always wear safety goggles!**

Your materials are available at most Home & Garden or Hardware stores

For workshop, kit and Project Plan Info contact Rick at:

<http://toyworkshop.com>

eMail: [hartman@toyworkshop.com](mailto:hartman@toyworkshop.com)

or: [toymaker@dwij.org](mailto:toymaker@dwij.org)



## WHY TOYMAKING?

In this high-tech age, when t.v., computers and video games consume so much of our children's attention, it's great to see kids in my workshops rolling up their sleeves and enjoying the simple pleasures of pounding nails, making sawdust and drilling holes through scraps of wood in order to construct their own playthings. Despite fears that young people in America are slipping into a state of lethargy, I've observed the opposite: Kids today seem eager, even hungry, to participate in these kinds of hands-on, purposeful activities.

Our challenge today is to discover the ways to engage kid's minds. I've discovered that toymaking is one such activity.

**Rick Hartman**

Catapult Toy Project © 2000 Rick Hartman

### WELCOME TO OUR TOYMAKING PROJECT

#### First Assemble Your Supplies!

**STEP 1:** Use your saw to cut thru your yard stick exactly on the 12" mark as shown on the left. You now have two sticks, one SMALL and one BIG.

**STEP 2:** Attach the BIG CUP to the end of the BIG STICK and the SMALL CUP to the SMALL STICK using the brass paper fasteners.

**STEP 3:** Find the pre-drilled hole in the middle of the BIG STICK. Use your hammer and carpet tack to attach the fulcrum block to the BIG STICK as shown on the left.

**NOTE:** Be sure that the fulcrum block is hammered to the SAME SIDE of the stick as the cup; like the picture on the right. **NOT THE OPPOSITE SIDE!**

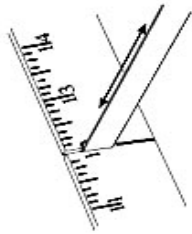

BIG CUP goes on BIG STICK:

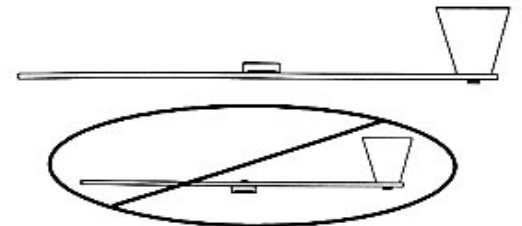
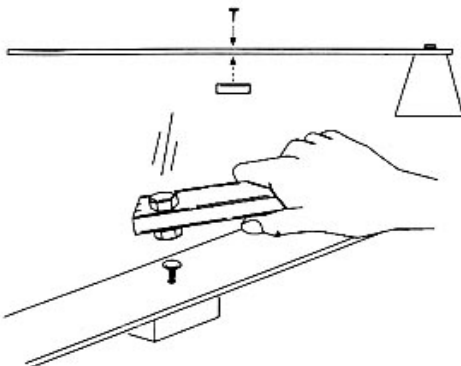
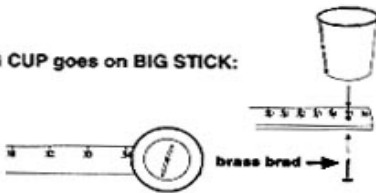

**Your project looks like this**

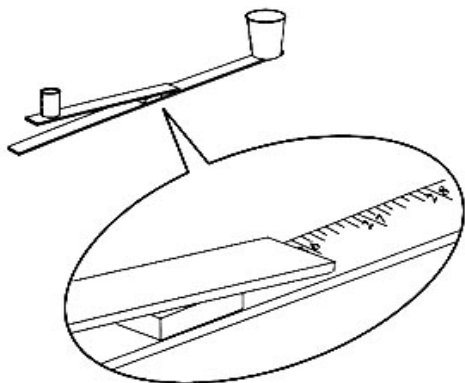

**STEP 4:** Use electrical tape to **TIGHTLY WRAP** the two sticks together. It is important that you stretch and pull the tape as tightly as possible with each wrap.

**ART IDEA:** Because yardsticks are marked every 1/8", you can create wonderful, color patterns on your toy using colored markers: Stripes, Zig-Zags and Diamonds. Use your imagination and create art patterns like those on the right.

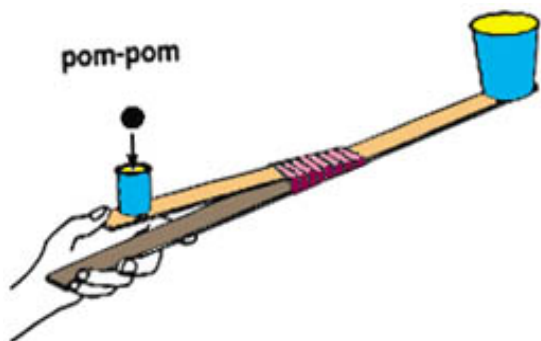
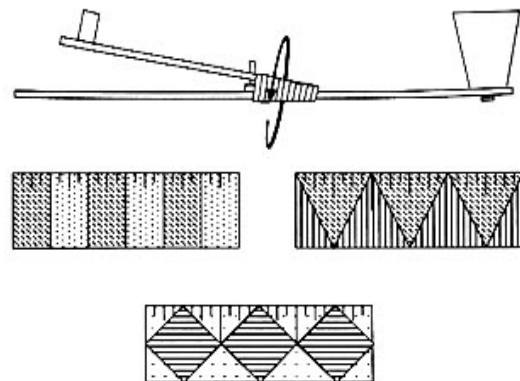

**WELL DONE!!!!**  
**CONGRATULATIONS**  
**ON COMPLETING**  
**YOUR TOY!!!**

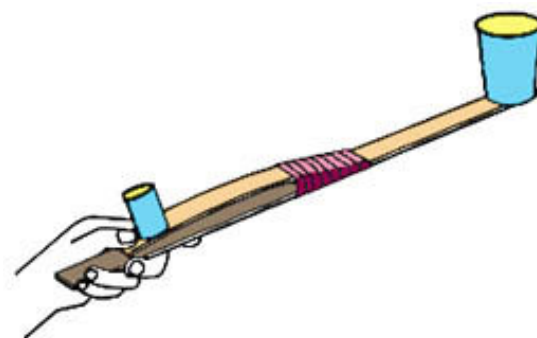

## FOLLOWING ARE INSTRUCTIONS ON PLAYING WITH YOUR CATAPULT

**1 . . . PLACE POM-POM IN CAN**

**2 . . . PRESS DOWN WITH YOUR THUMB SO BOTH STICKS TOUCH**

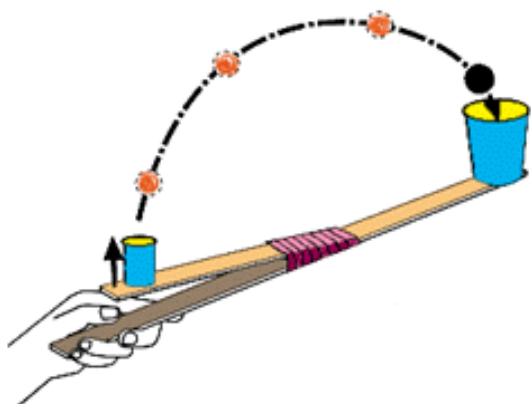

**3 . . . LET YOUR THUMB SLIP OFF THE SMALL STICK SO THAT IT SPRINGS UP AND LAUNCHES THE POM-POM TOWARD THE BIG CUP. CATCHING THE POM-POM IN THE CUP TAKES A BIT OF PRACTICE.**

**Here's a Tip:** IF YOUR TOY DOES NOT HAVE ENOUGH SPRING, REWRAP THE TAPE BEING SURE THE TWO STICKS ARE TIGHTLY BOUND TOGETHER

### GAME IDEAS:

- TRY TO CATCH THE POM-POM TWO, THREE, OR FOUR TIMES IN A ROW
- LAUNCH YOUR POM-POM INTO ANOTHER PERSON'S WAITING CUP
- SEE HOW MANY TIMES YOU CAN CATCH IT IN A GIVEN PERIOD OF TIME
- TOSS THE POMPOM BACKWARDS FROM THE BIG CUP TO THE SMALL CUP.

THANKS FOR TRYING YOUR TOY BUILDING SKILLS • RICK

[For Information Contact: toymaker@dwij.org](mailto:toymaker@dwij.org)